



Size range

Standard and special inch and metric sizes are available from 3/8" to 18" outer diameter

Load Capacity

Typical dynamic loads: 4,000 to 20,000 psi Ultimate strength: 60,000 psi for G-10 washer substrate.

Motion

The thrust washer works well in oscillatory and slow speed full rotation. Alternate configurations work well in linear sliding applications.

Friction

Duralon® bearings offer low-friction operation. Friction decreases with increasing load. Friction coefficients vary from .16 @500 psi to .07 @ 20,000 psi.

Self-lubricated

The bearing is constructed with woven Teflon® fiber. Teflon® is deposited on the mating surface during the start up phase and provides lubrication. Lubrication can be added if desired. Consult a Rexnord engineer for approved lubricants.

Washer Construction

The thrust washer is constructed by bonding woven Teflon® fiber fabric liner to one or both faces of a washer substrate. The substrate may be metallic, such as low carbon steel, stainless steel or aluminum. It may also be a non-metallic substrate such as NEMA grade G-10 or NEMA grade C. Standard washers are made with G-10 substrate.

Electrical Properties

The Duralon® G-10 substrate material is an electrical insulator. Its dielectric strength is about 550 volts per mil. Since the back-up material is electrically non-conducting, electrolytic or galvanic action will not take place between it and the housing or the shaft.

Chemical Properties

Duralon® thrust washers are typically resistant to most chemicals. Due to the wide range of exposures, specific conditions must be checked. Consult a Rexnord engineer for specific chemicals.

Thermal Properties

Duralon® thrust washers can be used in temperatures ranging from cryogenic to + 250 °F.

Technical Data

Due to the variety of substrate materials that can be used to make Duralon thrust washers, consult with Rexnord engineers for technical data.

DURALON THRUST WASHERS

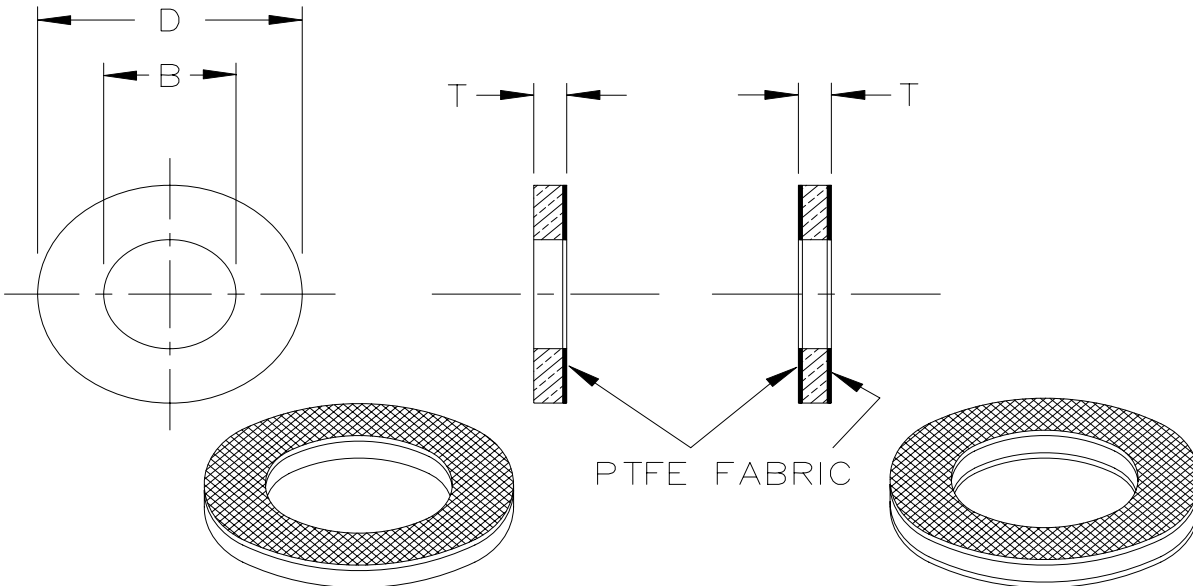

NOMINAL SHAFT DIAMETER	* MODEL NUMBER		B + .020 - .000	D + .000 - .020	T +/- .005
	LINED ONE FACE	LINED BOTH FACES			
.250	707-00008-002	707-20008-002	.270	.500	.062
.312	707-00010-002	707-20010-002	.332	.625	.062
.375	707-00012-002	707-20012-002	.395	.750	.062
.437	707-00014-002	707-20014-002	.457	.875	.062
.500	707-00016-002	707-20016-002	.520	1.000	.062
.625	707-00020-002	707-20020-002	.645	1.250	.062
.750	707-00024-002	707-20024-002	.770	1.500	.062
.875	707-00028-002	707-20028-002	.895	1.750	.062
1.000	707-00032-002	707-20032-002	1.020	2.000	.062
1.125	707-00034-002	707-20034-002	1.145	2.125	.062
1.250	707-00036-002	707-20036-002	1.270	2.250	.062
1.375	707-00040-002	707-20040-002	1.395	2.500	.062
1.500	707-00042-002	707-20042-002	1.520	2.625	.062
1.625	707-00044-002	707-20044-002	1.645	2.750	.062
1.750	707-00046-002	707-20046-002	1.770	2.875	.062
1.875	707-00048-002	707-20048-002	1.895	3.000	.062
2.000	707-00052-002	707-20052-002	2.020	3.250	.062

NOMINAL SHAFT DIAMETER	* MODEL NUMBER		B + .020 - .000	D + .000 - .020	T +/- .005
	LINED ONE FACE	LINED BOTH FACES			
.250	707-00008-004	707-20008-004	.270	.500	.125
.312	707-00010-004	707-20010-004	.332	.625	.125
.375	707-00012-004	707-20012-004	.395	.750	.125
.437	707-00014-004	707-20014-004	.457	.875	.125
.500	707-00016-004	707-20016-004	.520	1.000	.125
.625	707-00020-004	707-20020-004	.645	1.250	.125
.750	707-00024-004	707-20024-004	.770	1.500	.125
.875	707-00028-004	707-20028-004	.895	1.750	.125
1.000	707-00032-004	707-20032-004	1.020	2.000	.125
1.125	707-00034-004	707-20034-004	1.145	2.125	.125
1.250	707-00036-004	707-20036-004	1.270	2.250	.125
1.375	707-00040-004	707-20040-004	1.395	2.500	.125
1.500	707-00042-004	707-20042-004	1.520	2.625	.125
1.625	707-00044-004	707-20044-004	1.645	2.750	.125
1.750	707-00046-004	707-20046-004	1.770	2.875	.125
1.875	707-00048-004	707-20048-004	1.895	3.000	.125
2.000	707-00052-004	707-20052-004	2.020	3.250	.125

* FOR MADE TO ORDER PARTS, CHECK WITH THE FACTORY